

SAMTM
Speedy Accuracy Maintainability

SFC1480FX
SFC2480FX series



Passing along the tradition from F to FX, a



SFC1480FX SFC2480FX series



From F to FX: Passing along the tradition

Since the first of our SFC480 series, SAM brand high-performance mass flow controllers have been carrying forward a tradition. We use a waveform diaphragm made of a Ni-Co alloy (YET[®]101), developed by Hitachi Metals, which also proves that we are a manufacturer of high class metal materials. By employing this excellent diaphragm in the flow rate control valve, the key component in a mass flow controller, we incorporate a simple valve design that does not use any sliding sections and reduces the occurrence of particulate contamination. With a high corrosion resistance and stable control performance, we leave the competition behind and our customers satisfied.



Diaphragm valve

Our flow rate sensor, another key component in mass flow controllers, employs a coil type thermal sensor based on technology we have been accumulating for half a century, and it is extremely reliable. In the SFC1480F series, thanks to the latest digital control technology, we have developed a dual-range mass flow controller, and a hybrid mass flow controller in which digital control technology reaches its peak. Our reputation is solid because our customers feel we offer an incomparable product.

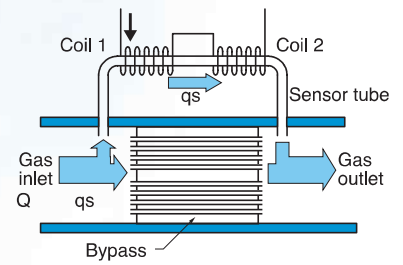

Basic design of the sensor

By inheriting the full tradition of the SAM brand, the SFC1480FX/SFC2480FX series are our most advanced models.

Circuit

- Less overshoot
- High speed response: 0 to 100%; 1.0 sec. max.
0 to 20%; 1.5 sec. max.
- Guaranteed precision when actually measuring gas

Sensor

- Larger diameter that doesn't clog easily
- Ni-free sensor (standard)
- Ni sensor for CIF3, HF

Housing material

- SUS316L (standard)

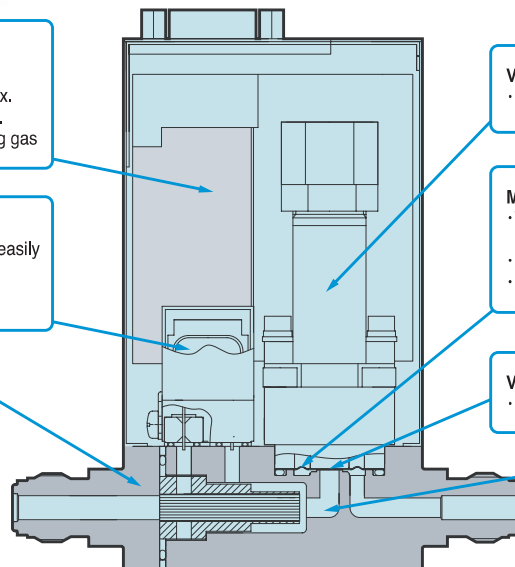

Valve actuator

- Uses a layered-piezoelectric element

Metal diaphragm

- Waveform Ni-Co alloy diaphragm (A proprietary development of Hitachi Metal)
- Extremely corrosion-proof with stable control
- No sliding surfaces and less creation of particles

Valve orifice

- Simple flow route

Surface finish

- Our unique, special electro-polishing

bold advancement to the next generation.

A bold advancement into the next generation, from G to FX

Conceptual diagram of the MG/MR (multi-gas/multi-range) mass flow controller

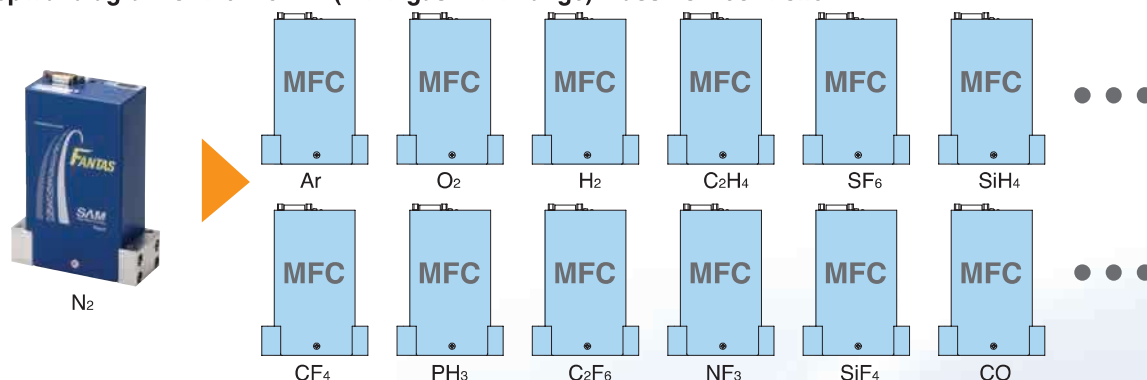

While inheriting the tradition of our earlier mass flow controllers, the SFC1480FX/SFC2480FX series is a bold advance into the next generation. The major element of innovation in this new series is the combination of many new technologies derived from the development of the G series all-in-one mass flow controller, in a new, next generation mass flow controller.

One core technology that has been fed back from this development is the MG/MR (multi-gas/multi-range) function. In conventional mass flow controllers, one controller could only handle one type of gas and one full scale flow rate range. This means that customers needed to have another mass flow controller for each different system, and for each different process recipe.

Since the FX series flow rate controller is equipped with the MG/MR function, and by preparing up to 14 recipes (full scale ranges of 2 SCCM to 50 SLM) to match the intended flow range, you can change the gas type and flow rate to match the actual gas you want to handle. When connected to a personal computer, the metering conditions can be changed instantly (See page 6).

Hitachi Metals actual gas flow rate accuracy guarantee system backs up this MG/MR function. A conventional mass flow controller only guarantees the flow rate precision with N₂ gas. To get the flow rate conditions for your actual gas using a conventional MFC, a conversion factor must be used as a coefficient to convert the flow rate.

Abbreviation	Standard full-scale flow rate range (N ₂ equivalent)
MG/MR	Flow range
FR-01	2~5 SCCM
FR-02	6~14 SCCM
FR-03	15~27 SCCM
FR-04	28~38 SCCM
FR-05	39~71 SCCM
FR-06	72~103 SCCM
FR-07	104~192 SCCM
FR-08	193~279 SCCM
FR-09	280~754 SCCM
FR-10	755~2037 SCCM
FR-11	2038~5500 SCCM
FR-12	5501~11000 SCCM
FR-13	11001~30000 SCCM
FR-14	30001~50000 SCCM

The reference values for these coefficients have been based of a variety of values, including calculated values, actually measured values, and empirical values. And, these were merely guidelines or reference values with some gas types. Although the MG/MR function is included, if the gas data deviates from the characteristics of the actual gas, the mass flow controller cannot perform as its designed level. With the FX series mass flow controller, in addition to the flow rate reference for N₂ gas (that ensures conformance with the national standard using the conventional gravimetric method), we installed full scale actual gas metering and exhaust gas processing facilities at our factory. Using these facilities, measurement is made for each type of gas at each full-scale range, and record the data. This is then used as actual gas data.

The advancements in the FX series are not limited to the features above.

The PI (Pressure Insensitive) function improves the controller's ability to tolerate variations in the primary pressure. This function improves durability and is currently highly desired in mass flow controllers. The G1 series was developed from the G series as a mass flow controller containing a PI pressure sensor. The FX series inherited the PI technology of the G1 series. Although the FX series models do not have a pressure sensor, they employ a sensor method and housing that can be used with the new PI technology. So, even though the FX series is not as advanced as the G1 series with its full scale PI function, they have greater PI performance by design, when compared with the existing F series.



N₂ gas reference flow rate



Actual gas flow rate measurement facility

SFC1480FX / SFC2480FX series

For both the 1.5" and 1.125" IGS MG/MR Mass Flow Controllers



Dimensions

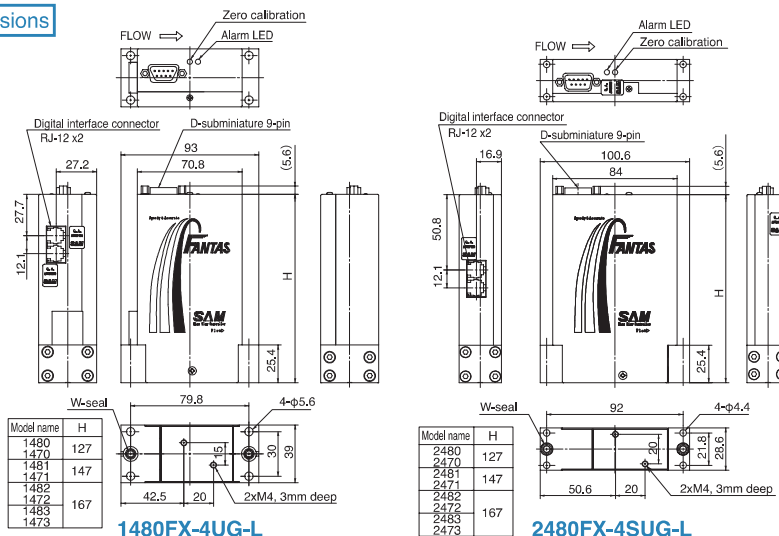

Item		Specifications *1			
Model name		SFC1480FX SFC2480FX	SFC1481FX SFC2481FX	SFC1482FX SFC2482FX	SFC1483FX SFC2483FX
Standard full scale flow rate (N ₂ equivalent)		5SCCM ~5,500SCCM	~11SLM	~30SLM	~50SLM
Function		Multi-gas/multi-range			
Valve operation		Normally closed / normally open			
Flow rate control range		2~100% F.S.			
Operation pressure *2	Inlet pressure	0.05~0.3 MPa (G) 7.3~43.5 PSI (G)		0.1~0.3 MPa (G) 14.5~43.5 PSI (G)	0.2~0.3 MPa (G) 29.0~43.5 PSI (G)
	Outlet pressure	Vacuum to ambient pressure			
Proof pressure		1.0 MPa (G) 145 PSI (G)			
Temperature	Operation	5~50 °C			
	Accuracy guaranteed	15~35 °C			
	Heating temperature when not powered	65°C maximum			
Humidity		35~80%RH (non condensing)			
Installation position		Horizontal, Vertical	Horizontal, Vertical (option)		
Accuracy	N ₂ gas	10~100%	± (0.5% S.P. + 0.15% F.S.)		
		2~10%	±0.2% F.S.		
	Actual gas	10~100%	± (1.5% S.P. + 0.35% F.S.)		
		2~10%	±0.5% F.S.		
Linearity	N ₂ gas	±0.3% F.S.			
	Actual gas	±1.0% F.S.			
Repeatability	10~100%	± (0.1% S.P. + 0.05% F.S.)			
	2~10%	±0.06% F.S.			
Flow rate sensor guaranteed zero point deviation range		±0.5% F.S. / year, max.			
Temperature dependence	Zero point	±0.01% F.S. / °C (15~35 °C)			
	Span	±0.01% S.P. / °C (15~35 °C)			
Response Time	0% → (20~100%)	Max. 1.0 sec. to reach ±2% S.P. of the set value.			
	0% → (2~20%)	Max. 1.5 sec. to reach ±0.4% S.P. of the set value.			
External leakage standard		Max. 1x10 ⁻¹¹ Pa · m ³ /s (He)			
Flow rate setting signal		0.1 to 5 VDC (absolute rating: Max. ±15 VDC)			
Flow rate output signal		0 to 5 VDC (maximum output: ±15 VDC)			
Required power		+15 VDC ±4%, 140 mA max -15 VDC ±4%, 140 mA max			
Material of gas wetted surface	Housing, flange, valve seat	SUS316L			
	Diaphragm	YET101 (Ni-Co alloy)			
	Flow sensor	SUS316L			Ni
	Seal *3	SUS316L			
Surface finish of components that contact the gas		Specially electro-polished (standard)			
Fitting *4		W seal, C seal, H1G seal, 1/4" HMJ (UJR) male			

*1: The specifications above are guaranteed values when the MFC was measured by itself in standard conditions. The MFC may not meet the specifications above, depending on the measurement conditions.

*2: The SFC147*FX/SFC247*FX are also available for use with minute pressure differences. Please inquire separately for the specifications of our minute pressure difference models.

*3: A model using a rubber seal is also available. Please inquire separately about the rubber seal specifications.

*4: An H1G seal is only available on the SFC14**FX series

SFC1480FX-D / SFC2480FX-D series

DeviceNet™ communication type For both the 1.5" and 1.125" IGS **MG/MR Mass Flow Controllers**



Dimensions

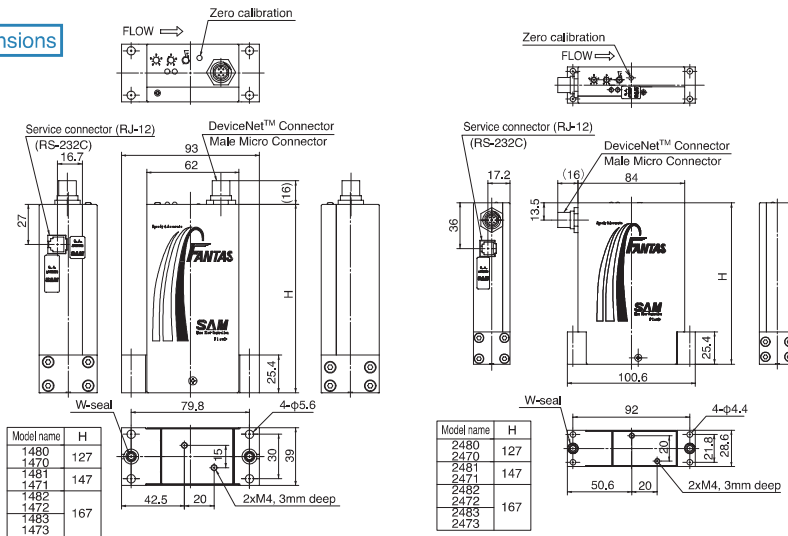

1480FX-4UG-D

2480FX-4SUG-D

Item		Specifications *1			
Model name		SFC1480FX-D SFC2480FX-D	SFC1481FX-D SFC2481FX-D	SFC1482FX-D SFC2482FX-D	SFC1483FX-D SFC2483FX-D
Standard full scale flow rate (N ₂ equivalent)		5SCCM ~5,500SCCM	~11SLM	~30SLM	~50SLM
Function		Multi-gas/multi-range			
Valve operation		Normally closed / normally open			
Flow rate control range		2~100% F.S.			
Operation pressure *2	Inlet pressure	0.05~0.3 MPa (G) 7.3~43.5 PSI (G)		0.1~0.3 MPa (G) 14.5~43.5 PSI (G)	0.2~0.3 MPa (G) 29.0~43.5 PSI (G)
	Outlet pressure	Vacuum to ambient pressure			
Proof pressure		1.0 MPa (G) 145 PSI (G)			
Temperature	Operation	5~50 °C			
	Accuracy guaranteed	15~35 °C			
	Heating temperature when not powered	65°C maximum			
Humidity		35~80%RH (non condensing)			
Installation position		Horizontal, Vertical	Horizontal, Vertical (option)		
Accuracy	N ₂ gas	10~100%	± (0.5% S.P. + 0.15% F.S.)		
		2~10%	±0.2% F.S.		
	Actual gas	10~100%	± (1.5% S.P. + 0.35% F.S.)		
		2~10%	±0.5% F.S.		
Linearity	N ₂ gas	±0.3% F.S.			
	Actual gas	±1.0% F.S.			
Repeatability	10~100%	± (0.1% S.P. + 0.05% F.S.)			
	2~10%	±0.06% F.S.			
Flow rate sensor guaranteed zero point deviation range		±0.5% F.S. / year, max.			
Temperature dependence	Zero point	±0.01% F.S. / °C (15~35 °C)			
	Span	±0.01% S.P. / °C (15~35 °C)			
Response Time	0% → (20~100%)	Max. 1.0 sec. to reach ±2% S.P. of the set value.			
	0% → (2~20%)	Max. 1.5 sec. to reach ±0.4% S.P. of the set value.			
External leakage standard		Max. 1x10 ⁻¹¹ Pa · m ³ /s (He)			
Flow rate setting signal		DeviceNet™ communication *3			
Flow rate output signal					
Required power		+24 VDC, 0.3 A max			
Material of gas wetted surface	Housing, flange, valve seat	SUS316L			
	Diaphragm	YET101 (Ni-Co alloy)			
	Flow sensor	SUS316L			Ni
	Seal *4	SUS316L			
Surface finish of components that contact the gas		Specially electro-polished (standard)			
Fitting *5		W seal, C seal, H1G seal, 1/4" HMJ (UJR) male			

*1: The specifications above are guaranteed values when the MFC was measured by itself in standard conditions. The MFC may not meet the specifications above, depending on the measurement conditions.

*2: The SFC147*FX/SFC247*FX are also available for use with minute pressure differences. Please inquire separately for the specifications of our minute pressure difference models.

*3: For information about DeviceNet™ communication, see page 6.

*4: A model using a rubber seal is also available. Please inquire separately about the rubber seal specifications.

*5: An H1G seal is only available on the SFC14**FX series

How to use the MG/MR conversion program

Gas type and flow rate can be converted using an MG/MR conversion program. Connect the mass flow controller to a personal computer using a digital communication cable, and use our proprietary program. One can convert the data easily with a simple GUI interface program. Following the program instructions, first select the gas type, and then flow rate units. A flow rate range will appear, and it can be changed. Enter a flow rate value and the setting is complete.

Users can change the gas type and flow rate.

<MG/MR conversion program> Select the correction amount data according to the gas type and flow rate you want to control

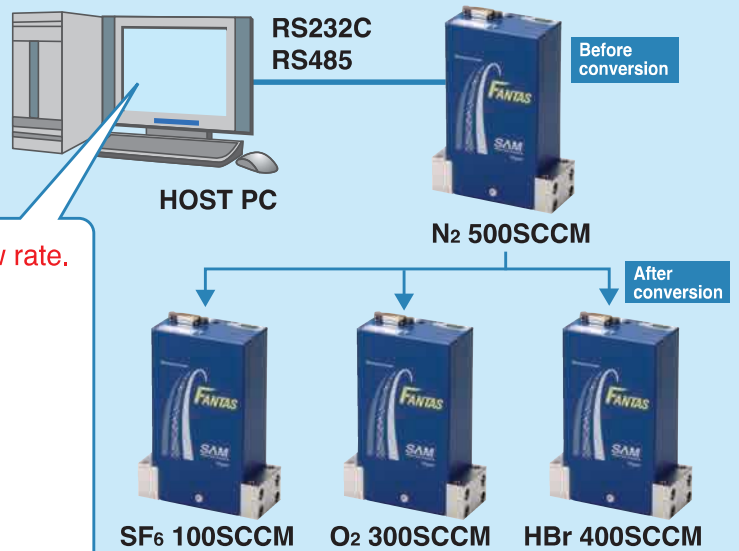

Simple operation to set the gas type and flow rate.

Select a gas type

The flow rate range is displayed (user settable).

Enter a flow rate

A screen that shows the program is converting.

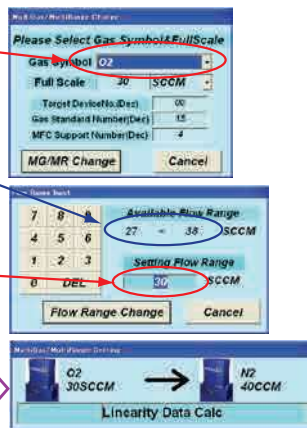

* For details about the operation, see the instruction manual

Models compatible with the DeviceNet™ communication system

About DeviceNet™

This is a field network recognized world wide, and it is approved as a standard sensor bus by the SEMI.

Field devices can be connected using serial communication in place of an I/O connection, allowing transfer of a large volume of data effectively.

The DeviceNet™ specifications are administrated by the ODVA (Open DeviceNet Vendor Association, Inc.) a non-profit body established to promote the spread of this system world-wide.

What are the advantages of employing DeviceNet™

- 1) By using serial communication from an I/O connection, one does not need an AD / DA / O board which can decrease configuration and set up costs.
- 2) Only network cables are needed and this reduces cabling costs, which decreases required man-hours, shortening engineering periods, and avoids problems from incorrect wiring.
- 3) DeviceNet™ employs a CAN (Controller Area Network) as a communication controller, and you can use a variety of CAN error detection functions.
- 4) The DeviceNet™ specifications are administrated by the ODVA, and have been normalized as international standards by IEC and SEMI. With this normalization, they are completely open, and lots of control devices are available from multiple vendors. You can choose the optimum device for your application.
- 5) The power for DeviceNet™ is only +24 VDC. You do not need to supply ± 15 VDC for the mass flow controller.

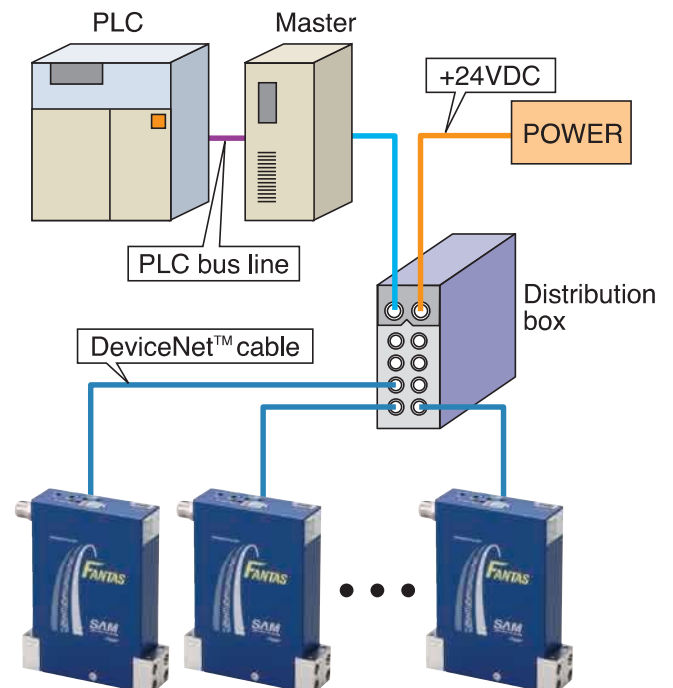

Communication connector pin assignment

Analog interface connector (D-Sub 9-pin)

Connector used : D-Subminiature, 9-pin connector (M3 screw)

Compatible plug : 17JE-13090-02 (D8B) (made by DDK) or equivalent

1) Connector model : L type

Pin number	Function
1	Valve open/close input (+15 VDC = Fully open; -15 VDC = Fully closed)
2	Output (0 to 5 VDC)
3	+15 VDC
4	COM (± 15 VDC)
5	-15 VDC
6	Input (0.1 to 5 VDC)
7	COM (output)
8	COM (Input)
9	Valve voltage (0 to 5VDC)

2) Connector model: Q type

Pin number	Function
1	Valve Full open (operate by connecting to COM)
2	Out put (0 to 5 VDC)
3	+15 VDC
4	COM (± 15 VDC)
5	-15 VDC
6	Input (0.1 to 5 VDC)
7	COM (output)
8	COM (Input)
9	Valve Full-close (operate by connecting to COM)

Digital interface connector

Connector used : 43814-6621 (made by Molex) (RJ-12 x 2 connectors)

Pin number	Signal name	
	RS232C	RS485
1	COM (Signal)	
2	No Connection	
3	Rxd	RS-
4	Txd	RS+
5	N.C.	
6	N.C.	

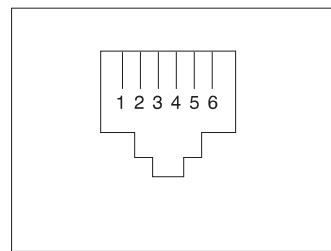

Note 1 : Rxd, Txd: RS232C Input and output

Note 2 : RS-, RS+: RS480 Input and output

DeviceNet™ connector

Connector used : DeviceNet™ Male Micro Connector (CM02-8DR5P(D5) made by DDK, or equivalent)

Pin number	Signal name
1	Drain
2	V+
3	V-
4	CAN_H
5	CAN_L

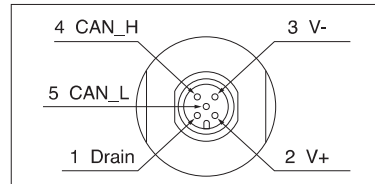

Additional functions

Function name	Description	Setting and reading methods
Alarm function	See the item for the alarm function	By command
Flow sensor zero reset function	Reset the flow sensor zero	By command or when the switch on the top is pressed
Lamp response function	Reset the flow rate using a specified time for the step flow rate setting.	By command
Flow control valve voltage monitor output function	Set the flow control valve opening (0 to 5 VDC)	By command or analog voltage output (only L type)
Flow control valve fully open / close function	Open and close the flow control valve completely	By command, ± 15 VDC, or contact point connection

Alarm function

Alarm cause	Alarm LED display	Alarm output condition
Normal operation	Green LED blinks at 1 Hz	No alarm
Flow rate setting does not the match flow rate output	Red LED lights	The mis-match between the flow rate setting and the flow rate output is 10% or more of the full scale and has continued for 10 seconds or longer
Abnormal ± 15 VDC power supply	Turns off	The ± 15 VDC power supply is outside the range of ± 12 VDC to ± 17 VDC, and has been for 0.5 seconds or longer.
EEPROM access error	Red LED lights	Abnormal value in the EEPROM data.
Digital communication error	Red LED goes on	Did not receive a normal digital command
Change in flow rate control status (Change from the preset status) · Flow rate setting changed · Flow rate output changed · Flow control valve open level changed · Abnormal zero point correction value for the flow sensor	Red LED blinks at 2 Hz	The change in the preset value was 10% or more of the full scale and continued for 10 seconds or longer. Or, the cumulative value of the zero point correction amount for the flow sensor is more than $\pm 20\%$ of full scale



Precautions to ensure safe use

In order to use our products safely, make sure to read the relevant instruction manuals before use.

SFC1480FX/SFC2480FX series ordering information

Model name							
Controller or meter	Size	Temperature	Pressure	Flow range	Series	Seal	Operation
SFC	1	4	8	2	FX	M	C

SFC	Mass flow controller						
FMT	Mass flow meter						
	1	1.5" size					
	2	1.125" size					
		4	Normal temperature type				
		5	High temperature type (80°C)				
		6	Ultra-high temperature type (150°C)				
			8	Normal pressure type			
			7	Low inlet pressure type			
				0	5~5,500 SCCM (FR-01~11)		
				1	11 SLM (FR-12)		
				2	30 SLM (FR-13)		
				3	50 SLM (FR-14)		
					FX	Multi gas, multi range, digital	
						M	Metal seal
						R	Rubber seal
						Blank	Mass flow meter
						C	Normally closed
						O	Normally open

Optional code					
Fitting	Connector	Gas-contact surface finish	Communication method	Protocol	Flow sensor material
4UG	L		B	L	N
4V *	1/4" HMJ (UJR) male				
4UG	1.5" W				
4AG	1.5" C				
4H1G **	1.5" H1G seal (Hitachi IGS seal)				
4SUG ***	1.125" W seal				
4SAG ***	1.125" C seal				

L	D-sub 9-pin (top mount), valve fully open / fully closed signal, ± 15 VDC type
Q	D-sub9 (top mount), valve fully open / fully closed signal, COM connection type
T ***	D-sub 9-pin (upstream side), digital output type
D	DeviceNet™
Blank	Special electro-polished
K	Machine processed finish
Blank	RS232C or DeviceNet™
B	RS485
Blank	SAM protocol or DeviceNet™
L	protocol

Note: * Can measure a 124 mm gap between the faces of a 1/4" HMJ (UJR) male.

** Only the SFC1480FX series can be used with a 4H1G fitting

*** Only the SFC2480FX series can be used with 4SUG, 4SAG fittings and a T connector

Blank	Ni free
N	Ni sensor

SAM™·FANTAS®·YET®101 is a registered trademark of Hitachi Metals, Ltd.



<http://www.hitachi-metals.co.jp>

Head Office
Piping Components Business Unit
Sales Dep. of Fine Flow
Shinagawa Season Terrace, 2-70, Konan 1-chome, Minato-ku, Tokyo 108-8224 Japan
Tel.+81-3-6774-3530 Fax.+81-3-6774-4348

Sales agent:

- The contents of this pamphlet are correct as of Jan 2016.
- The specification, appearance, etc. of products listed in this pamphlet may be changed without prior notice.
- Due to printing reasons, the product colors in this pamphlet may be different from the actual product colors.
- This pamphlet is copyright 2007 by Hitachi Metals Ltd., all rights reserved. Duplication of any part of the contents without prior written approval is strictly prohibited.
- If you have questions about anything described in this pamphlet, please contact the address shown on the left.
- DeviceNet™ is a registered trademark of ODVA.
- We are not liable for and do not accept responsibility for any loss, direct or indirect, caused by incorrect use, careless handling, force majeure, war, terrorism, fire, pollution, use in unapproved environments, salt damage, or any natural disasters (such as wind or flood damage, earthquakes or lightning), or for any consequential damage.

The above contact numbers are subject to change. If you cannot reach us using those numbers, please try the following:
Hitachi Metals, Ltd. Toll-free 0800-500-5055 (in Japan), Tel.+81-3-6774-3001
All rights reserved.